

SINCE 1908
wessels
company

INSTALLATION & OPERATION
TYPE : GLYCOL MAKE-UP PACKAGE

INSTALLATION:

1. Install the make-up package base assembly (6) on a level and sturdy surface. 50 gal. unit weighs 440 lbs full of solution, 100 gal. unit weighs 843 lbs full of solution.
2. Screw the outlet valve (3) into the solution container (2) outlet. Place outlet valve (3) to the left. Connect the hose assembly (5) to the outlet valve (3).
3. Pipe-in the 1/2" FNPT System valve (7) to the System or loop to be pressurized.
4. Fill the solution container (2) with glycol and water in the proportions specified and mix.
5. Connect the panel electric cable to the junction box, according to local codes. The pump motor and the controls run on 120/1/60.
6. With the system isolation valve (7) turned "off", turn the power "on" and monitor the pump pressure: the pressure gauge should rise and the pump should stop after approximately 30 seconds. The gauge will indicate the factory PRV pressure setting. If necessary, reset the pressure reducing valve, as described on the reverse side of this form, so that this pressure is equal to the fill or minimum pressure required for the system to be pressurized.
7. Fill the System with the specified solution by other means. Make sure that the System pressure is equipped with an adequate system expansion tank and a relief valve in order to protect the closed circuit components. The relief valve outlet can be discharged through the lid (1) into the solution container for glycol recovery.
8. Open the System valve (7). The pump will cycle, as required, to maintain a positive pressure. It will not run on an empty solution container (2). During the initial purge of the System, keep a close watch on the glycol solution supply so that the container is never empty.
9. A 120 V signal is available from the low level sensor (4) for a distant alarm.

OPERATION:

1. Once the System has been purged, the GMP will maintain the set make-up pressure automatically.
2. The GMP Series is designed to operate without the need of servicing or adjustment. No lubrication is necessary; the pump is equipped with self-lubricating carbon bearings, and the motor is a life-time lubricated type for standby make-up applications. For other service, see nameplate. The pump has a mechanical seal type which does not require adjustment.
3. Make sure that the glycol solution level in the translucent solution container (2) is adequate at all times. On GMP Series, should the solution container run dry, the pump will stop and the alarm will be activated. The audible part may be silenced; however, make sure it is turned back on after filling the tank and bleeding as in paragraphs 5 and 6 above. Always replace the lid (1) to keep the solution clean.

101 TANK ST., GREENWOOD, IN.
tel.: (317) 888-9800
fax: (317) 888-9988
www.westank.com

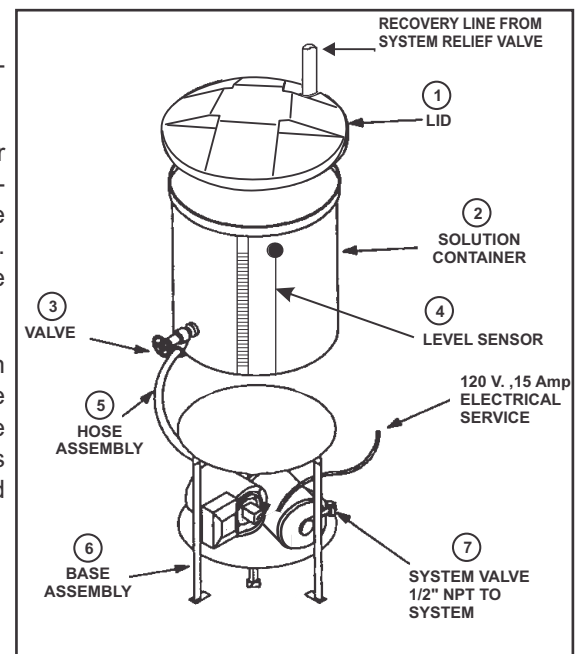

GMPAW
110316

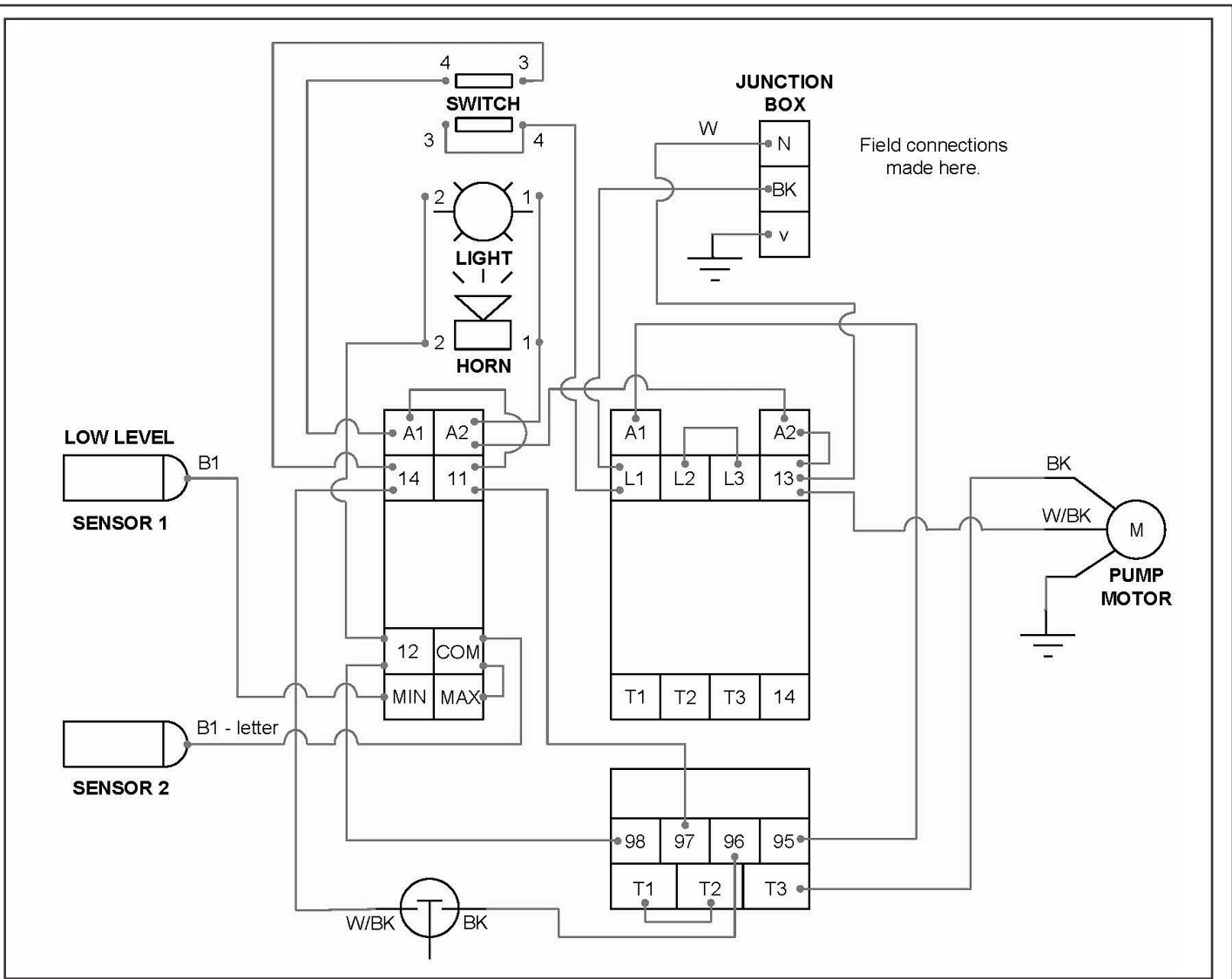

! WARNING

To change the GMP discharge pressure to the system, adjust only the Pressure Reducing Valve (10 to 70 PSI).

PRESSURE REDUCING VALVE ADJUSTMENT

The Pressure Reducing Valve (PRV) is factory set for a unit discharge pressure of 12 psig. If a different discharge pressure is required, adjust the PRV as follows.

A. INCREASING THE PRV DISCHARGE PRESSURE.

1. With the GMP unit operating, close the GMP's isolation valve (7).
2. Loosen the lock nut on the PRV adjustment screw.
3. While observing the GMP's discharge pressure gauge, turn the PRV adjustment screw in a clockwise direction until the desired operating pressure is achieved.
4. While holding the PRV adjustment screw in its new set position, tighten the lock nut.
5. Return the isolation valve to its full open position.

B. DECREASING THE PRV DISCHARGE PRESSURE.

1. Open the system relief valve to obtain a lower pressure than the one desired, do the steps mentioned in section "A".

PARTS LIST

Part No.	Item	Part No.	Item
GMP-1/3STARTER	Magnetic Starter 1/3 HP	GMP-XT15	Pressure Tank
GMP-1/2STARTER	Magnetic Starter 1/2 HP	GMP-PUMP	Pump Only
GMP-LVM25	Low Level Relay	GMPMOT-3-MOTOR	1/3 HP Motor
GMP-PRV	Pressure Reducing Valve	GMPMOT-2-MOTOR	1/2 HP Motor
GMP-PSWITCH	Pressure Switch	GMP-50TANK	50 Gal. Solution Tank
GMP-GAUGE	Pressure Gauge	GMP-100TANK	100 Gal. Solution Tank

101 TANK ST., GREENWOOD, IN.

tel.: (317) 888-9800 • fax: (317) 888-9988 • www.westank.com