

SINCE 1908  
**wessels**  
company

**GMP**  
Glycol Make-up Package

INSTRUCTION

## GMP6 / 18 HYDRONIC SYSTEM FEEDER





## GMP6 / 18

# INSTALLATION, OPERATION AND MAINTENANCE

The GMP can be used with heating or cooling systems. It is used to maintain the system at a specific pressure. The GMP should be used to pressurize the system when it is at its lowest temperature.



### Installation Instructions

Do not install a pressure regulator or check valve between system feeder and the system.

Ensure that there is a system isolation valve to isolate the system feeder.

GMP6 / 18:

**Max pressure at 412.8 kPa (60 PSI)**

Factory set at 82.5 kPa (12 PSI)

### Operation Verification

It is important to check the proper functioning of each component before final connection.

1. Make sure the tank is free of dirt.
2. Check the operation of the pump.
  - A) Connect the pump directly into a wall outlet.
3. Check the operation of the pump/float assembly.
  - A) Make sure that the float shaft is upright (90°) and that the float can move freely.
  - B) Manually lift the float to ensure free movement of ball in the float.

4. Check the overall operation of the unit.

- A) Connect unit to system and close system isolation valve.
- B) Plug the pump to the wall outlet.
- C) Fill tank with solution mix of glycol/water – up to 50% glycol (we recommend a non-toxic propylene-based glycol).
- D) Open unit circulation valve (pump should start) to verify that the pump works properly.
- E) Close unit circulation valve and open system isolation valve.

## SYSTEM START-UP

1. Install the system feeder on a levelled and sturdy surface, or on optional wall mounting bracket (#GMP6WMS, for GMP6 only).
2. Fill system feeder tank with correct fluid required for system operation.

## USE OF AN INDEPENDANT SOLUTION CONTAINER FOR FILLING

**NOTE:** Do not plug in the unit until step D, as instructed below.

The GMP is equipped with a 3-way valve facilitating system filling (**photo 1**).

- A) Fill the GMP tank with the least amount of solution so the float is activated. (3.5 US Gal/13 L for both GMP6 and GMP18).
- B) With a flat head screwdriver, turn the valve so it rotates 90° counterclockwise, until the valve indicator points to the independent tank (**photo 2**).
- C) Install a hose on the valve to link the independent tank to the pump.

**WARNING:** the pump self-primers up to a maximum of 8 feet. It is important to stay within this range to use the GMP pump to fill your system. It is recommended to use Calefactio's filling kit. (#GMPFILLINGKIT).

- D) Plug the pump into the piggyback, and then into an electrical outlet.
- E) The GMP pump will fill the system and stop. Once it has stopped, unplug the GMP from the electrical outlet.
- F) Place the valve back at "SYSTEM" position (**photo3**) and remove the hose.
- G) Plug the GMP back into the electrical outlet.
- H) Finalize system filling by raising it to the desired pressure level using the solution inside the GMP tank. Fill it manually if need be.

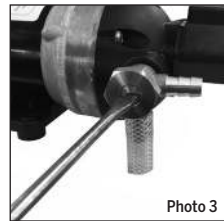
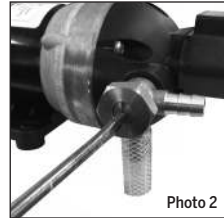
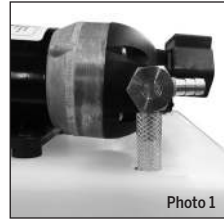

## OPEN SYSTEM ISOLATION VALVE. INSERT PUMP ELECTRICAL PLUG INTO PIGGYBACK SWITCH PLUG, AND INTO WALL OUTLET.

**NOTE:** The pressure gauge on system feeder may indicate a different pressure than a gauge installed elsewhere in the system. This difference may be due to calibration variations, or elevation differences and is normal.

3. If the system pressure is below the pressure reducing valve (PRV) setting, the pump will start. The pump will run until the system is pressurized to the PRV setting. The pump may cycle rapidly.
4. If a higher system pressure is required, adjust the PRV to the desired value as follows:

- A) Close the isolation valve.
- B) Loosen the lock nut.

C) Turn the screw clockwise until the gauge displays the desired pressure.

D) Hold the screw and tighten the lock nut.

(The standard system feeder PRV can be adjusted to 60 PSI.)

5. To get to a lower pressure, open the security valve and let the pressure go down below the desired pressure. From there, follow the steps stated in #4.

# MAINTENANCE

The GMP requires no scheduled maintenance.

## → System pressure is below set point.

POSSIBLE CAUSE	CORRECTIVE ACTION
System isolation valve closed.	Open the system isolation valve.
System is unplugged.	Plug the system in the wall outlet.
No power to the system.	Verify that the wall outlet has power.
Low liquid level in the tank. Float has stopped the system.	Add fluid. Find the source of the leak and repair.
Pressure reducing valve out of adjustment.	Adjust the PRV.
Control piggyback float not operating properly.	Verify operation of float. Ensure that the float moves freely.
Defective pressure gauge.	Check pressure using another gauge. Replace defective gauge.
Pump motor failure.	Replace pump.

## → Pump does not prime.

POSSIBLE CAUSE	CORRECTIVE ACTION
External check valve or regulator installed between system and feeder.	Remove the check valve or regulator.
Pump is air locked.	Bleed the supply line.

## → Pump cycles continuously.

POSSIBLE CAUSE	CORRECTIVE ACTION
Air is being removed from the system and replaced with liquid.	Allow sufficient time for air removal. The pump will stop operating when air is removed.
External check valve or regulator installed between system and feeder.	Remove the check valve or regulator.
Control level piggyback float switch is not stopping the pump.	Ensure that the float is operating properly and that it is not held in the closed position (floating).
Leak in system.	Find source of the leak and repair.

# CONNECTION DIAGRAM

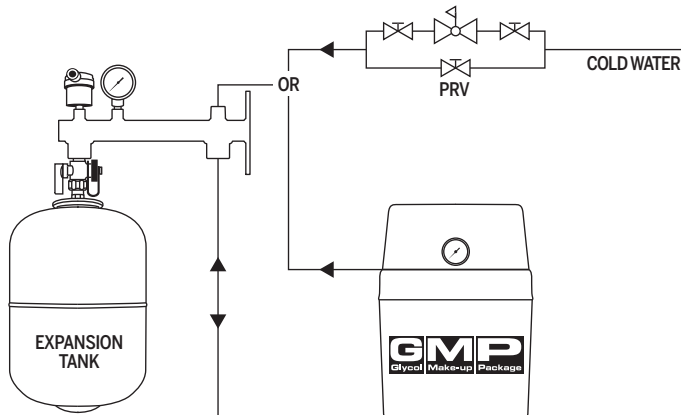

# GMP6-18 PARTS

REF.	DESCRIPTION	PART #
1	Pump	GMP-PUMP
2	Tank	GMP-TANK-6*
2	Tank	GMP-TANK-18**
3	Gray cover	GMP COVER
4	Cap	GMP-LID
5	Piggyback float switch	GMP DOSER
6	Pressure reducing valve	GMP-BRASSPRV
7	3/8" MNPT x barbed fitting	GMP3WAY
8	Fitting 3/8" MNPT x 1/4" MNPT	GMP5052
9	1/8" MNPT x 1/4" barbed valve	GMP1103
10	4 1/2" Rigid black hose	XASBH4.5
11	1/4" x 3" Clear hose	GMP3606
12	Washer	GMPW146**
13	1" Stainless steel screw	GMPSCREW-10**
13	3/4" Stainless steel screws	GMPT1112S1*
14	Pressure gage	GAUGE0-100
15	Gear clamp	GMPCLAMP**
16	3/8" x 11 1/2" Hose	GMPFILLING-HOSE*
16	3/8" x 36" Hose	GMPFILLING-HOSE**
17	Strainer	GMP-STRAINER
18	Barbed x threaded fitting for strainer	GMP125-6C
19	1/2" PVC cross fitting	PVC4012CR
19	1/2" ø x 11 3/16" Pipe	PVC401210NP*
19	1/2" ø x 33 3/4" Pipe	PVC401210NP**
20	1/2" Male adaptor	GMP12AM
21	1" Black shutter	APHPO13A
22	1/2" MNPT Cap	GMPCAP
23	1/2" Clip	GMPCLAMP2
24	Grommet	GMP-GROMMET
25	O-ring	GMPORING*
26	8" Nylon clip	TW8**
27	Glued 1" x 3/4" plastic fitting	PVC4034M**

## OPTIONS

1B	Remote alarm panel c/w 9V battery	GMPAL
+2B		
2B	Remote alarm float/Dry contact	GMPDC
3B	Wall mounting shelf	GMP6WMS

\*GMP6 part only. \*\*GMP18 part only.

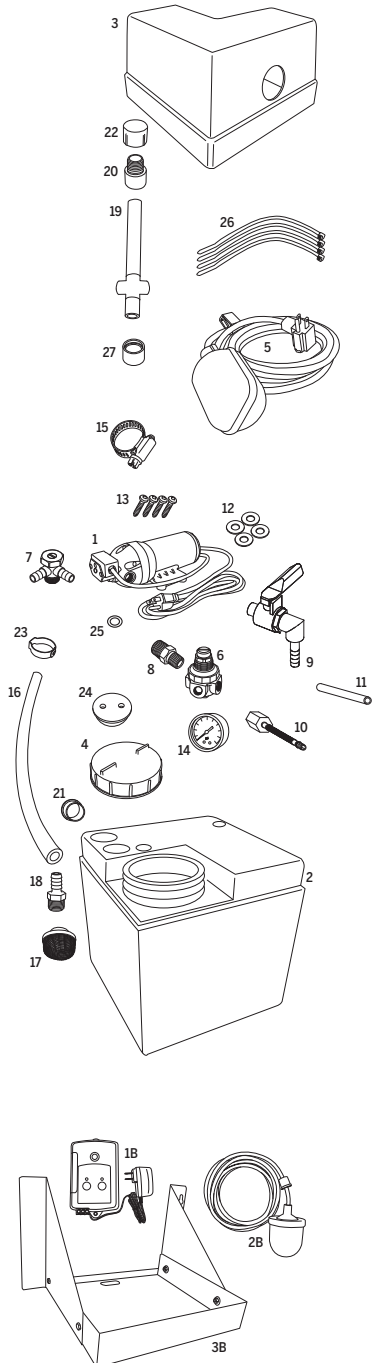

# WARRANTY

## 1 YEAR LIMITED WARRANTY ON GMP6-GMP18 FROM THE DATE OF PURCHASE OR 6 MONTHS AFTER FABRICATION DATE.

**Wessels Company** warrants to the original purchaser ONLY that the products subject to this sale, are free of material and workmanship defects, and conform to the specifications published by Wessels Company.

This warranty is only valid if the product is installed and used under normal working conditions, and for the purpose for which it was intended, given the terms and conditions listed below. If the buyer does not provide protective storage, does not install or maintain the equipment according to manufacturer's instructions, this warranty will become NULL and VOID. In the event that the buyer discovers a material defect or notices malfunctioning from the products, they must immediately notify the installer/distributor/store from which the product was purchased, who will, in turn, notify Wessels Company of the claim. Notifications for product malfunctions will not be received by Wessels Company past the timeframe given for the warranty, which is determined, based on the date the product was manufactured.

If requested by the manufacturer, prior to attempting any repairs, defective products or parts thereof must be promptly returned to one of the manufacturer's warehouses, or sent to an authorized service representative, as indicated by the manufacturer. The manufacturer accepts no responsibility for loss or damage to the product(s) while in transit, nor will any warranty claim be considered unless the returned goods are received in the exact condition they were in prior to shipping. Claims for damage due to shipping are the sole responsibility of the customer and must be resolved by the customer directly with the shipping carrier. Repaired or replacement products will be shipped to customer at FOB factory terms. The manufacturer warrants replacement parts for ninety (90) days or for the remainder of the warranty of the product that was repaired or replaced.

If a claim is deemed valid, the manufacturer's sole obligation under warranty shall be, at their own discretion, to repair or replace the defective product. NO cash refunds will be given. Wessels Company reserves the right to correct the malfunctioning of the product by using new or used replacement parts. Such repairs will be performed at Wessels Company expense. Wessels Company will NOT accept any claims from the customer for labour costs associated with the removal or reinstallation of the product and/or part thereof. No claims will be accepted for returned items which show obvious signs of repairs, alterations, and/or other modifications (to the product or any of its parts thereof) effected without first obtaining written authorization from Wessels Company. In the event that Wessels Company is unable to repair the product, Wessels Company will provide the buyer with a replacement product. While replacing parts or replacing the product itself, Wessels Company reserves the right to make changes in the design, construction or materials if it is deemed necessary to replace defective products with new models of the same equipment and/or upgrade the parts of any product judged to be defective.

Under the terms of this warranty, in no event shall the manufacturer be held responsible or liable for:

1. Consecutive, indirect or particular loss or damages. Such damages include, but are not limited to, loss of profits, loss of capital, loss of revenue or savings, loss resulting from the non-use of the product or of associated equipment, downtime, cost of substitute equipment, facilities or services, injuries, property damages or any claims of third parties (including the customer). Some states/provinces do not allow limitations or exclusions of indirect or consecutive damages; therefore this clause may not be applicable in certain cases.
2. Damages, defects or malfunctioning caused by a failure to install and maintain the product in accordance with the printed instructions that were included with the product.
3. Malfunction or damages due to abnormal conditions of use, accidents, mishandling, neglect or misuse of the product (i.e. using the product for purposes other than for which it was intended).
4. Loss, damage and/or labour costs incurred as a result of the improper installation or the installation of defective parts or inadequate repairs/service by others, using unauthorized attachments or modifications.
5. Damage caused by (including but not limited to) sand or abrasive materials, buildup of chemical products, mud, oily residues, acids, corrosion, mishandling or improper installation.
6. Damage caused by natural disasters such as fire, wind, earthquakes, and lightning.
7. Parts, components or products not manufactured by Wessels Company but used in conjunction with the products that are subject of this sale.
8. Any abuse or misuse by the customer.

All repairs and/or services performed by manufacturer for reasons other than those covered under this warranty will be charged according to the manufacturer's current equipment, parts and service fees.

Returned products or parts will NOT be accepted if returned to manufacturer without obtaining approval prior to shipment.

The present warranty is the sole warranty of the manufacturer. Any other warranties express or implied in law or in fact, including but not limited to, warranties of merchantability or fitness for particular purpose, are hereby specifically disclaimed.

Some states/provinces do not allow limitations on the duration of implied warranties; therefore, this clause may not be applicable to you. This warranty extends ONLY to the original purchaser and is therefore not transferable.