



SINCE 1908  
**wessels**  
 company

SUBMITTAL

**WVA TRIM PACKAGE**

Models: WVA-2 thru WVA-36  
 Submittal Sheet No. D-1123A

Date: 11/20

Job Name _____	Submitted By _____	Date _____
Location _____	Approved By _____	Date _____
_____	Order No. _____	Date _____
Engineer _____	Notes _____	
Contractor _____	_____	
Sales Rep. _____	_____	

**Description**

Wessels WessVent Trim Package is designed to remove the harmful air and contaminants normally found in a closed loop heating or cooling system. When installed, the trim package includes all essential parts for taking full advantage of the WessVent Air/Dirt Separator's potential.

**Performance Limitations**

Maximum Design Pressure: 150 PSI  
 Maximum Design Temperature: 240°F

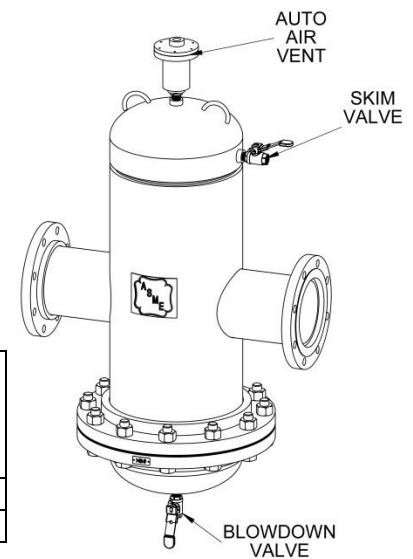

Model Number	Part Number	Tagging Information	Quantity
WVA-2 thru WVA-14	74099993		
WVA-16 thru WVA-36	74099995		

**Dimensions & Weights**

Model Number	Part Description	Quantity	Material	Approx Shipping Weight
WVA-2 thru WVA-14	#706 Air Vent	1	Cast Iron	9 lbs
	1" Ball Valve	1	Brass	
	1/2" Ball Valve	1		
	3/4" x 1/2" Bushing	1	Carbon Steel	
	1/2" x Close Nipple	1		
WVA-16 thru WVA-36	#706 Air Vent	1	Cast Iron	12 lbs
	2" Ball Valve	1	Brass	
	1" Ball Valve	1		
	1" x 3/4" Reducer Bushing	1	Carbon Steel	
	3/4" x Close Nipple	1		